

## Gond Multitex M16

*Gond à visser M16 ou à scellement chimique, pour une utilisation dans des matériaux creux utiliser un tamis.*

### Gond Multitex M16 / 35-60

– Embase et oreille cupro-aluminium brut ou poudré

Pivot Ø12, lg 25

Référence	Finition	Gencod 3661598	Cdt
NA619005	brut	00689 7	1
NA691005	9016	00935 5	25
NA692005	9005	01687 2	25

NA6XX005

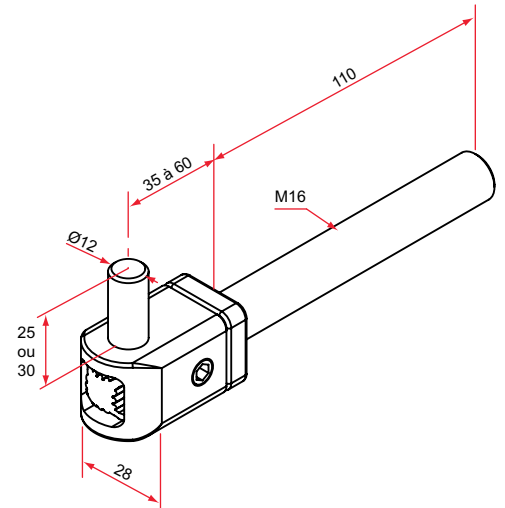
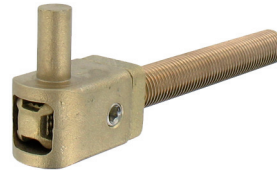

### Gond Multitex M16 / 35-60

– Embase et oreille, cupro-aluminium brut ou poudré

Pivot Ø12, lg 35

Référence	Finition	Gencod 3661598	Cdt
NA619015	brut	00699 6	1
NA691015	9016	00945 4	25
NA692015	9005	01696 4	25

NA6XX015

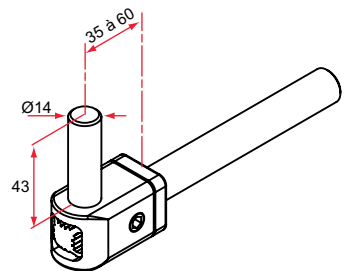
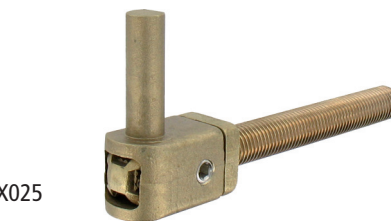

### Gond Multitex M16 / 35-60

– Embase et oreille, cupro-aluminium brut ou poudré

Pivot Ø14, lg 43

Référence	Finition	Gencod 3661598	Cdt
NA619025	brut	00709 2	1

NA6XX025

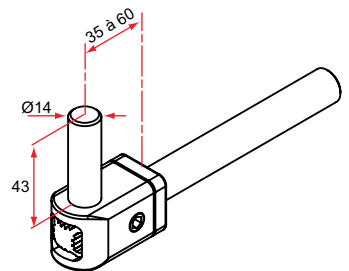
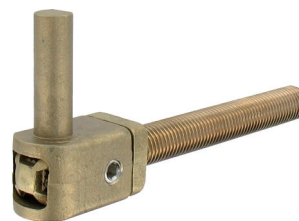

### Gond Multitex M16 / 35-70

– Embase et oreille cupro-aluminium brut ou poudré

Pivot Ø12, lg 25

Référence	Finition	Gencod 3661598	Cdt
NA619030	brut	01356 7	1
NA691030	9016	01361 1	25
NA692030	9005	01702 2	25

NA6XX030

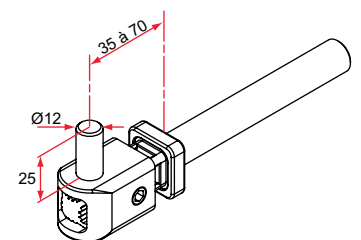
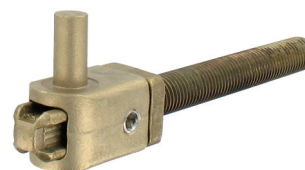

Gond disponible avec hauteur de pivot 35 mm, nous consulter.

### Gond Multitex M16 / 45-80

– Embase et oreille cupro-aluminium brutes ou poudrées

Pivot Ø12, lg 25

Référence	Finition	Gencod 3661598	Cdt
NA619010	brut	00694 1	1
NA691010	9016	00940 9	25
NA692010	9005	01692 6	25

NA6XX010

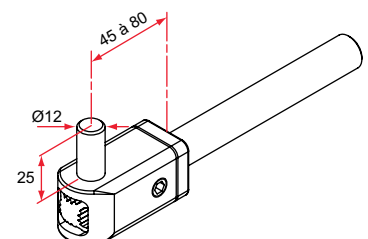
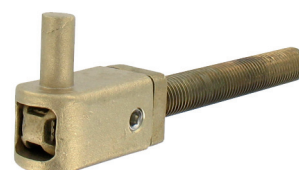

sur stock

sur Cde

sur devis

**TIRARD**

Tél. : 0 825 80 85 80 | Fax : 03 22 20 74 30