

Possible applications include :



PVC and Aluminum  
wing shutter  
accessories

## Features

- Aluminum body Painted or raw nail Crimping thickness: 6 to 14 mm



### Tip

- "The "raw" finish of the nail will preserve the crimping nose of your machines. Keep that in mind."

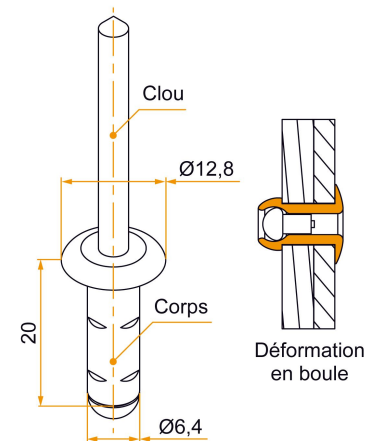

Products to be ordered from :  
BURGAUD SAS 147, rue des Paludiers Z.I. des Mares 85270 SAINT-HILAIRE-DE-RIEZ  
email : [commande@tirard-burgaud.com](mailto:commande@tirard-burgaud.com)

Possible applications include :



PVC and Aluminum  
wing shutter  
accessories

Référence	Finish	Nail finish	GENCOD 3565920	Condit. par	Délai j
VIU002N53	9005-30%	raw	20778 8	100	14
VIU002B68	9016-80%	raw	20779 5	100	14
VIU002RAL		raw	20027 7	50	14
3VI92021RAL		painted	19161 2	50	14

Multi-RAL : specify your color when placing the order (<https://www.couleursral.fr/ral-classic>)