

Possible applications include :

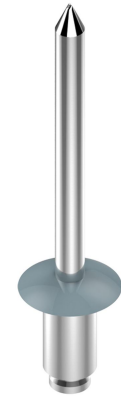

PVC and Aluminum
wing shutter
accessories



Features

- Aluminum body Raw nail Crimping thickness: 3 to 6 mm



Tip

- "The "raw" finish of the nail will preserve the crimping nose of your machines. Keep that in mind."

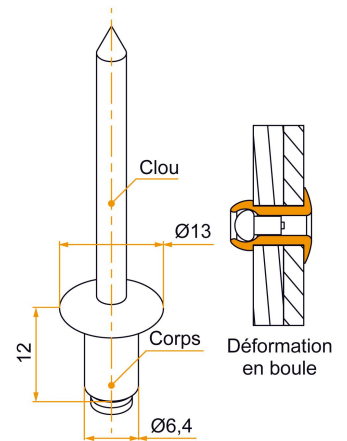

Products to be ordered from :
BURGAUD SAS 147, rue des Paludiers Z.I. des Mares 85270 SAINT-HILAIRE-DE-RIEZ
email : commande@tirard-burgaud.com

Possible applications include :



PVC and Aluminum
wing shutter
accessories



Référence	Finish	Nail finish	GENCOD 3565920	Condit. par	Délai j
VIU008RAL		raw	21286 7	50	14

Multi-RAL : specify your color when placing the order (<https://www.couleursral.fr/ral-classic>)